

Keystone Advantage™ Spindle Extension Kit

PLEASE CAREFULLY READ ALL OF THE
INSTRUCTIONS PRIOR TO INSTALLATION

The Keystone Advantage Latch is designed to fit the most common post sizes: from 1-3/4" up to 5". For applications where posts size exceed 5" dimension, The Spindle Extension Kit (Fig. 1) has been designed to fit up to 14" post.

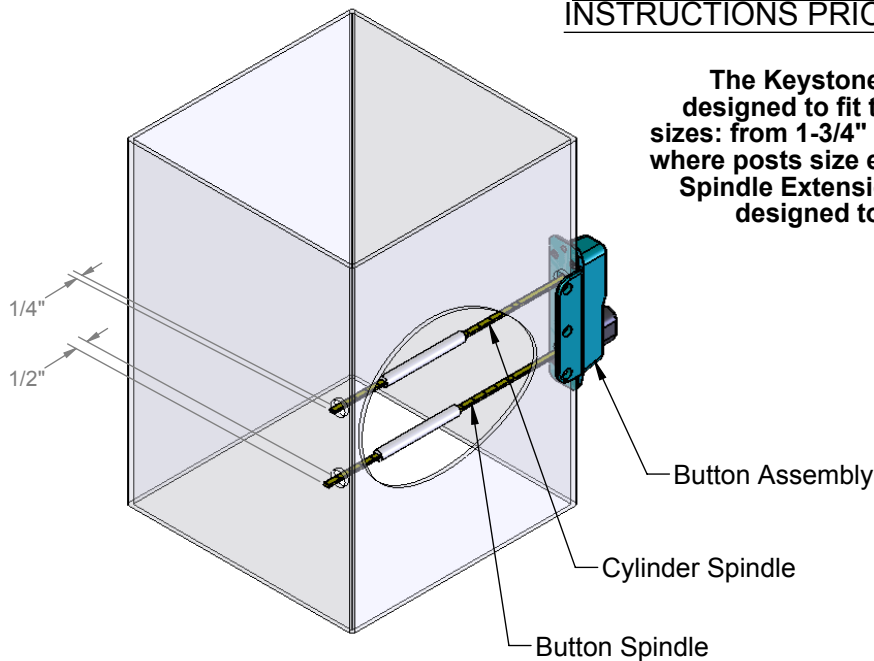

Fig. 2

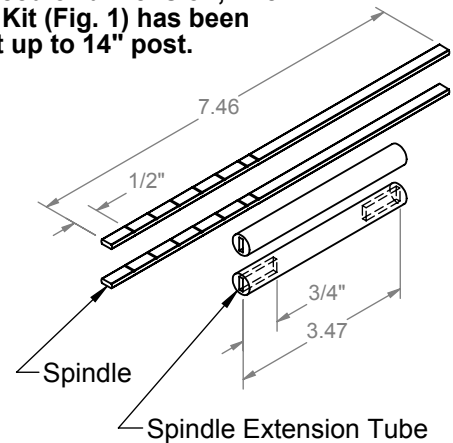

Fig. 1

STEP-1

Mark and drill holes per Keystone Advantage Instruction Sheet.

STEP-2

Attach the Spindles and Spindle Extension Tubes to the Button Assembly spindles as shown in Fig. 2. With Button Assembly positioned to post with the Button Spindle mounted through the lower hole and the Cylinder Spindle through the upper hole. The cylinder spindle should protrude through the post by 1/4" and the button spindle should protrude through the post by 1/2" without the button depressed. Mark and cut the Spindles. Avoid bending spindles during cutting process. Be sure the spindle tips are free from burrs and sharp edges. Attach the Button Assembly to post with the supplied screws.

STEP-3

Align the cylinder spindle so that it matches the mating slot in the latch assembly. The mating slot is in the top hole on the back of the latch assembly. With the button depressed, align the latch assembly with the spindles and slide into place as shown in Fig. 3. Be sure the latch is NOT in the LOCK position when testing. Holding the Latch Assembly in place, TEST the latch by depressing the button. When the Latch is not locked the latch knob can be used to lift the latch mechanism. Attach the Latch Assembly to the fence post with the supplied screws.

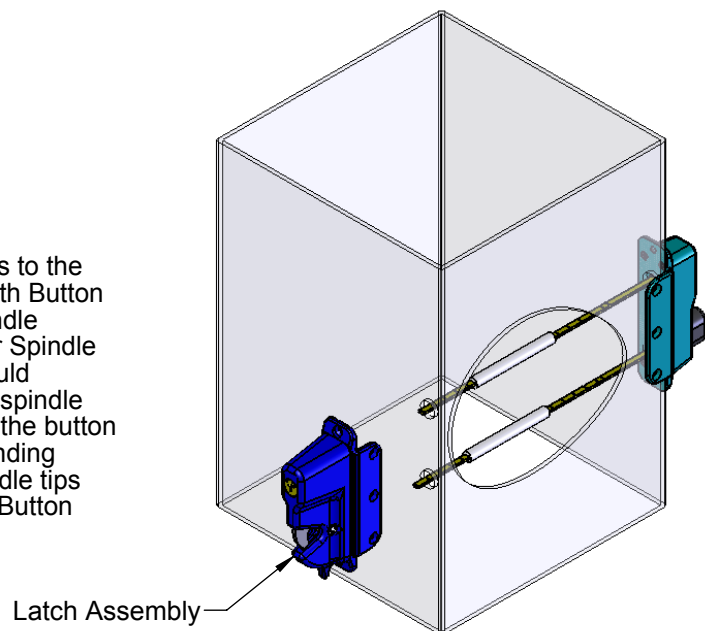

Fig. 3

STEP-4

After installing both the Button Assembly and the Latch Assembly, position and attach the Striker (See Installation Instruction Sheet). After installation, TEST the locking and unlocking of both the latch and button sides.