

SPL100

SIDE PULL LATCH

INSTALLATION, ADJUSTMENT AND MAINTENANCE INSTRUCTIONS

A gate bumper or other stop type **MUST** be used with this latch

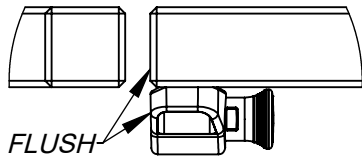

Step 1

- Check gate to ensure gap is between .32" - .47" (8mm - 12mm).
- Determine desired latch height.
- Position Latch Body on the gate at desired height and align flush with the edge.
- Attach Latch Body to gate with two screws. Screws should be centered in slot.

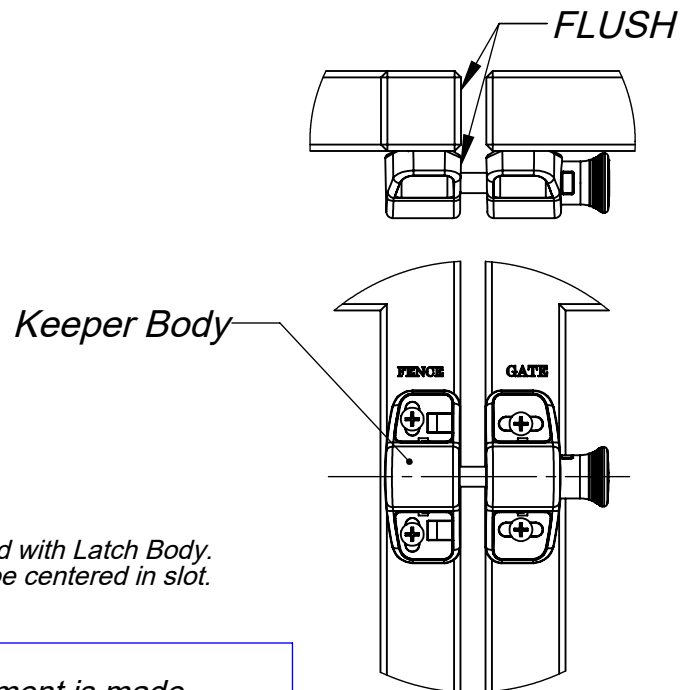
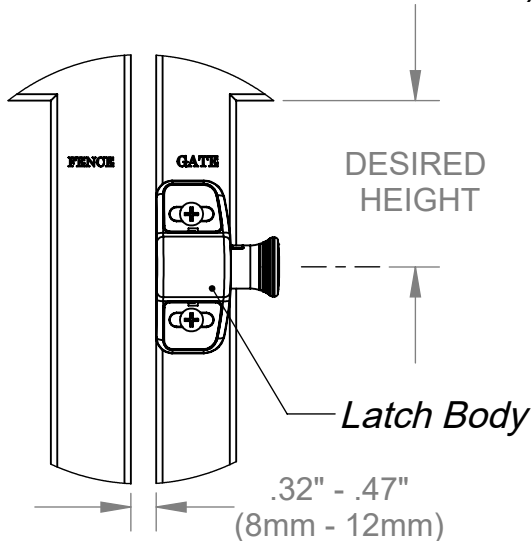

Step 2

- Position Keeper Body on fence side flush with edge and aligned with Latch Body.
- Attach Keeper Body to fence with two screws. Screws should be centered in slot.

Do not install caps until final adjustment is made

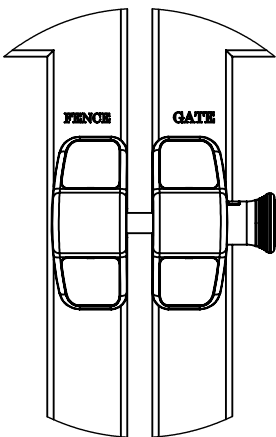

Step 3

- Check operation of latch thoroughly.
- Adjust position as necessary for proper operation.

To adjust latch

- Loosen screws
- Slide to new position
- Tighten screws.

Keeper body is vertically adjustable
Latch body is horizontally adjustable

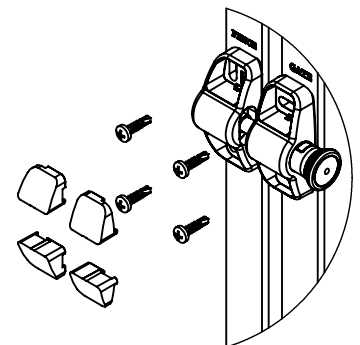

Step 4

- Install caps by pressing firmly

Maintenance

This latch should be inspected periodically for proper operation. Keep latch clean and free of foreign materials. Wash with mild detergent and water.