



PATENTED
THE KEYSTONE® 2
 NYLON GATE LATCH



HEAVY DUTY
 DESIGN



6-PIN
 CYLINDER



FITS RIGHT OR LEFT
 HANDED GATES



EASY
 INSTALLATION

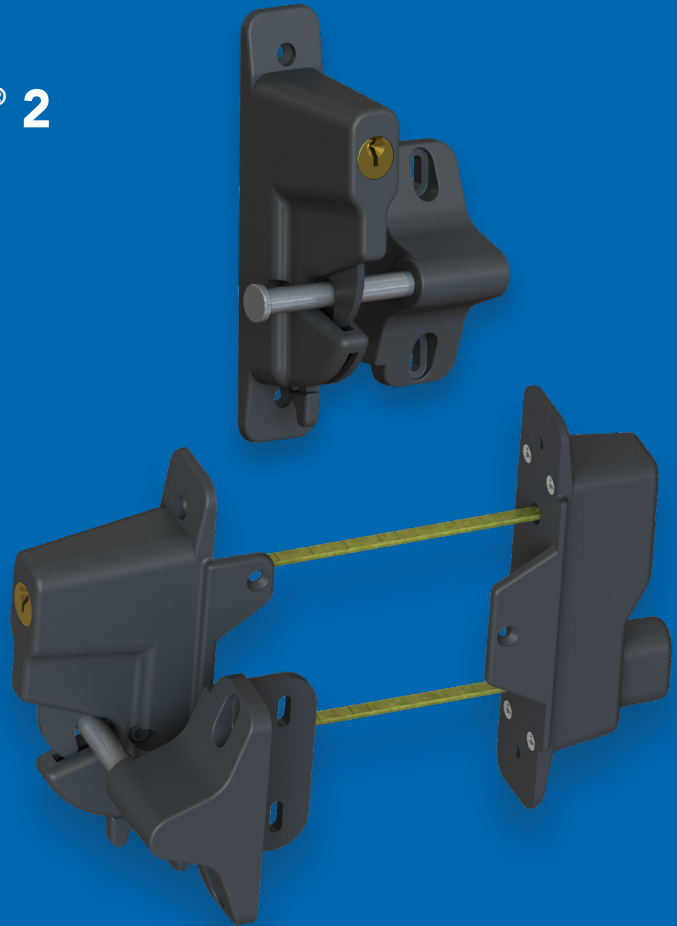

Part Number	Description	Count	Case Weight (lbs)
KLADV2-P1-BK	KEYSTONE® 2 LATCH, NYLON, Black, 1-sided, 6 pin	20	13
KLADV2-P1SD-BK	KEYSTONE® 2 LATCH, NYLON, Black, 1-sided, 6 pin, w/SD screws	20	13
KLADV2-P1ZD-BK	KEYSTONE® 2 LATCH, NYLON, Black, 1-sided, 6 pin w/ZD screws	20	13
KLADV2-P2-BK	KEYSTONE® 2 LATCH, Black, 2-sided 6 pin	20	17.5
KLADV2-P2SD-BK	KEYSTONE® 2 LATCH, Black, 2-sided, 6 pin, w/SD screws	20	17.5
KLADV2-P2ZD-BK	KEYSTONE® 2 LATCH, Black, 2-sided, 6 pin, w/ZD screws	20	17.5

