

Keystone® Advantage

KLADV-P2 (for 1-3/4" to 5" POST) &

KLADV-M2 (for 2" to 5" POST)

INSTALLATION, ADJUSTMENT AND MAINTENANCE INSTRUCTIONS

PLEASE CAREFULLY READ ALL OF THE INSTRUCTIONS PRIOR TO INSTALLATION

STEP-1

Use one of the following methods for locating the mounting holes required to install the latch. THESE INSTRUCTIONS APPLY TO ALL POST SIZES.

WITHOUT MOUNTING TEMPLATE

At the desired mounting height of the Keystone® Advantage on the Fence Post, mark the centerpoints of the 2 holes, 5/8" from post edge spaced by 2-11/16". Drill 5/8" diameter holes at both centerpoints (fig 1). IMPORTANT: HOLES MUST BE STRAIGHT AND LEVEL.

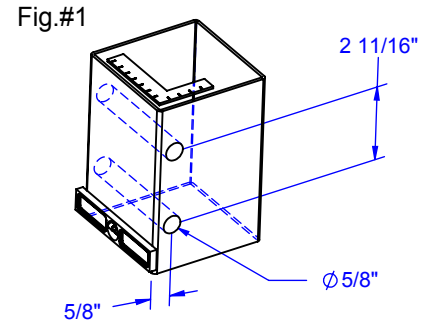

WITH MOUNTING TEMPLATE

Draw a level line at the desired height for the latch on the side of the post facing the gate. This line will locate the center of the latch when installed (fig 2).

Next, align the template so that the side with (3) holes is on the side of the post with the line. The line should be visible through the center hole of the template (fig 3). Mark all (7) holes provided in the template.

Reverse the template (fig 4) and align as described in previous step. Mark all holes in template.

Using marks created in previous steps, drill all (14) mounting holes. The two center spindle holes (fig 5) require a $\varnothing 5/8$ " hole. All other holes will be drilled to $\varnothing 1/8$ ".

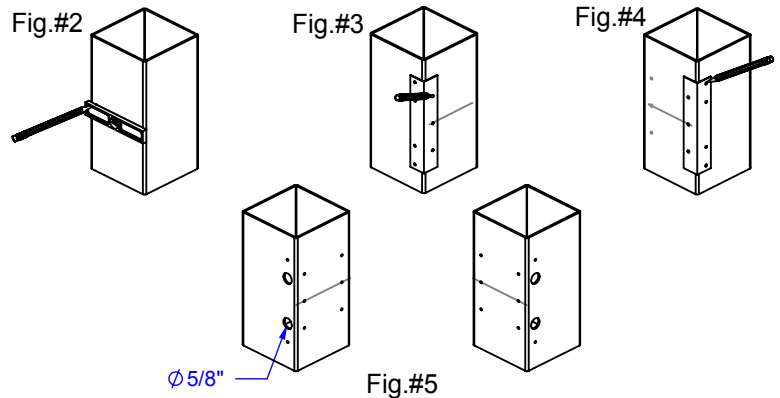

STEP-2

The Keystone® Advantage is designed to fit both right-hand and left-hand applications. To conform to your application both the button assembly (fig 6) and the latch assembly (fig 7) may need to be reversed. To reverse the button assembly: remove the four screws holding in the mounting base, carefully lift and rotate the mounting base. To reverse the latch assembly: remove the four screws holding the mounting base, carefully lift and rotate the mounting base. IMPORTANT: INNER COMPONENTS MUST NOT BE DISTURBED WHILE REVERSING THE ASSEMBLIES.

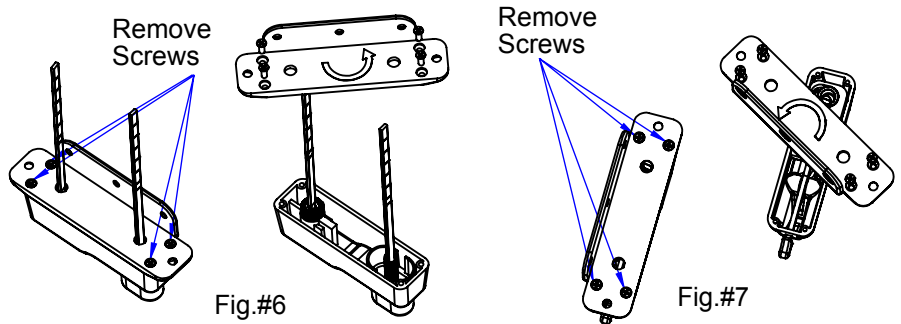

STEP-3

Pick fence post size from chart below. Keystone® Advantage is designed to fit many post sizes. IMPORTANT: BE CAREFUL TO AVOID BENDING SPINDLE DURING CUTTING PROCESS

Post Size	Cut Location on Spindles
1-3/4 X 3 1/2 ("P2" Type ONLY)	Cut at the Seventh Inscribed Cut Mark
2 X 2	Cut at the Sixth Inscribed Cut Mark
2 X 3 1/2	Cut at the Sixth Inscribed Cut Mark
3 X 3	Cut at the Fourth Inscribed Cut Mark
3 1/2 X 3 1/2	Cut at the Third Inscribed Cut Mark
4 X 4	Cut at the Second Inscribed Cut Mark
5 X 5	DO NOT CUT SPINDLE

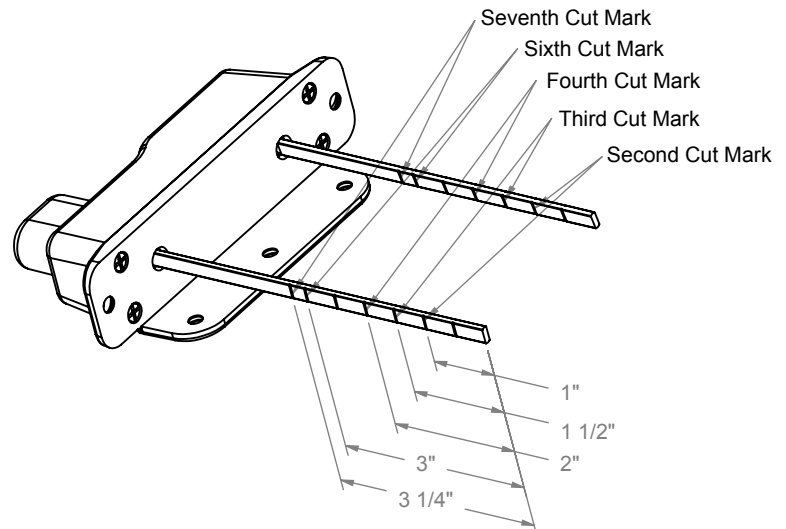

Keystone® Advantage KLADV-P2 & KLADV-M2

INSTRUCTIONS (CONT'D)

STEP-4

Attach the Button Assembly to the fence post with the Button Spindle mounted through the lower hole and the Cylinder Spindle through the upper hole. Without the button depressed the cylinder spindle should protrude through the post by 1/4" and the button spindle should protrude by 1/2". Be sure the spindle tips are free from burrs and sharp edges. Align the cylinder spindle so that it matches the mating slot in the latch assembly. The mating slot is in the top hole on the back of the latch assembly.

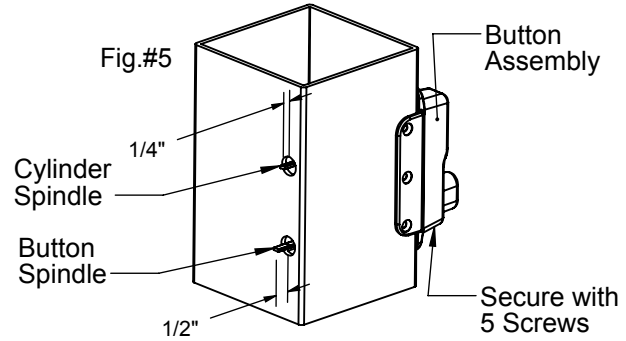

STEP-5

With the button depressed, align the latch assembly with the spindles and slide into place. Be sure the latch is NOT in the LOCK position when testing. Holding the Latch Assembly in place, TEST the latch by depressing the button. When the Latch is not locked the latch knob can be used to lift the latch mechanism. Attach the Latch Assembly to the fence post with the supplied screws.

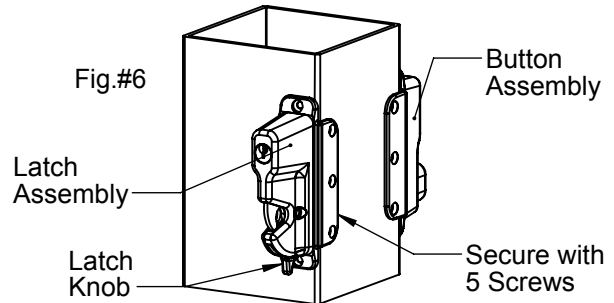

STEP-6

After installing both the button assembly and the latch assembly, position and attach the Striker. With the gate closed, position the striker with the Striker Rod within the latch assembly, behind the latch mechanism.

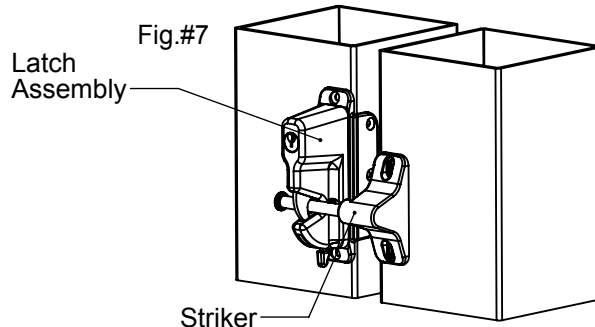

STEP-7

After installation, TEST the locking and unlocking of both the latch and button sides.

LATCH SIDE

Lock: Turn key clockwise to stop point, then counterclockwise to 12:00 O'Clock position and remove

Unlock: Turn key counterclockwise to stop point, then turn key clockwise to 12:00 O'Clock position and remove



BUTTON SIDE

Lock: Turn key counterclockwise to stop point, then turn key clockwise to 12:00 O'Clock position and remove

Unlock: Turn key clockwise to stop point, then counterclockwise to 12:00 O'Clock position and remove

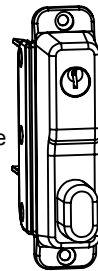

TROUBLESHOOTING

If the latch's lock feature fails to work as described in Step-7 then you will need to reverse the button side cylinder spindle.

To reverse the button side cylinder spindle:

- 1) Remove the keys from the latch.
- 2) Carefully remove the latch side from the post.
- 3) Rotate the button side cylinder spindle (shown in figure #5) 180°. This should only turn in one direction.
- 4) Reattach the latch to the post, taking care not to turn the cylinder spindle or cam inside the latch housing.

Once complete, check for proper operation.