

|         |      | REVISIONS       |          |      |
|---------|------|-----------------|----------|------|
| ECR/DCR | REV. | DESCRIPTION     | DATE     | APPD |
| -       | -    | INITIAL RELEASE | 12-14-23 | -    |

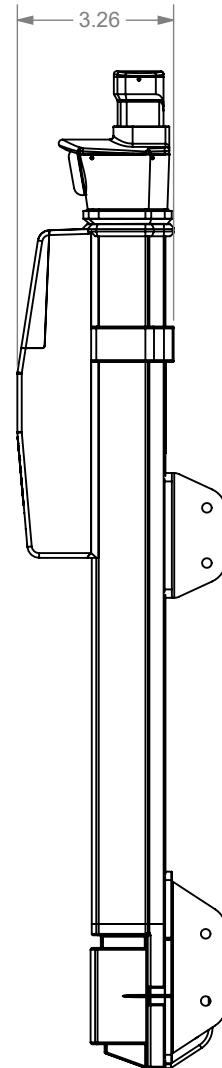
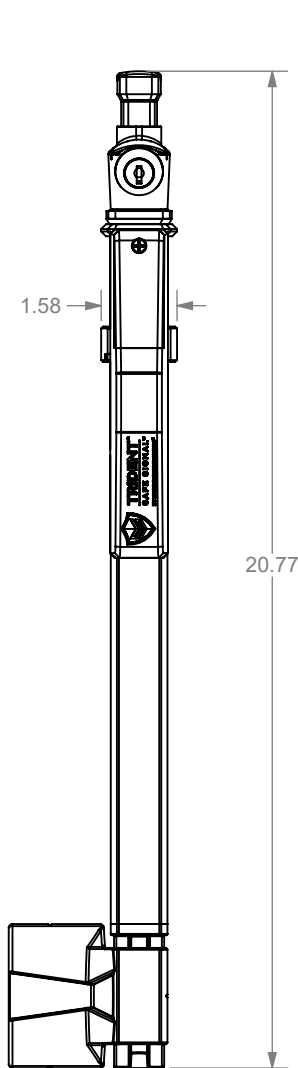
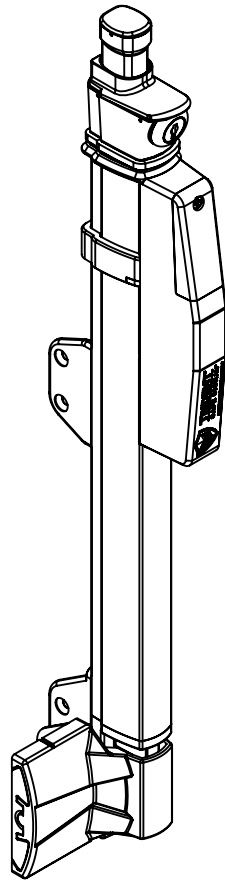

**PACKAGING INSTRUCTIONS**

**PACKAGE CONTAINS:**

- (1) LATCH AND MODULE ASSY
- (1) KEEPER
- (1) KEY SET WITH TAG
- (1) INSTRUCTIONS BOOKLET
- (1) ZIPPER BAG CONTAINING:
  - (1) CABLE HOUSING COVER
  - (1) UPPER MOUNTING BRACKET
  - (1) LOWER MOUNTING BRACKET
  - (1) M2.9 X 16MM FLAT HD PHILLIPS  
THREAD-FORMING SCREW
- POLYBAG CONTAINING:
  - (11) #10 X .75" FLAT HD PHILLIPS  
SELF-DRILLING SCREWS
  - (1) #8 X .38" FLAT HD PHILLIPS SCREW

DIMENSIONS ARE IN INCHES  
 TOLERANCES:  
 FRACTIONAL  $\pm 1/16"$   
 ANGULAR: MACH  $\pm 1^\circ$  BEND  $\pm 1^\circ$   
 TWO PLACE DECIMAL  $\pm 0.01$   
 THREE PLACE DECIMAL  $\pm 0.005$

**PROPRIETARY AND CONFIDENTIAL**  
 THE INFORMATION CONTAINED IN THIS  
 DRAWING IS THE SOLE PROPERTY OF  
 NATIONWIDE INDUSTRIES. ANY  
 REPRODUCTION IN PART OR AS A WHOLE  
 WITHOUT THE WRITTEN PERMISSION OF  
 NATIONWIDE INDUSTRIES IS PROHIBITED.

**TRIDENT™ SS  
 MAGNETIC  
 TOP PULL LATCH**

|            |                 |              |
|------------|-----------------|--------------|
| SIZE       | DWG. NO.        | REV.         |
| A          | CS--TRIDENTSS20 | -            |
| SCALE: 1:4 | WEIGHT:         | SHEET 1 OF 2 |

**KEEPER**

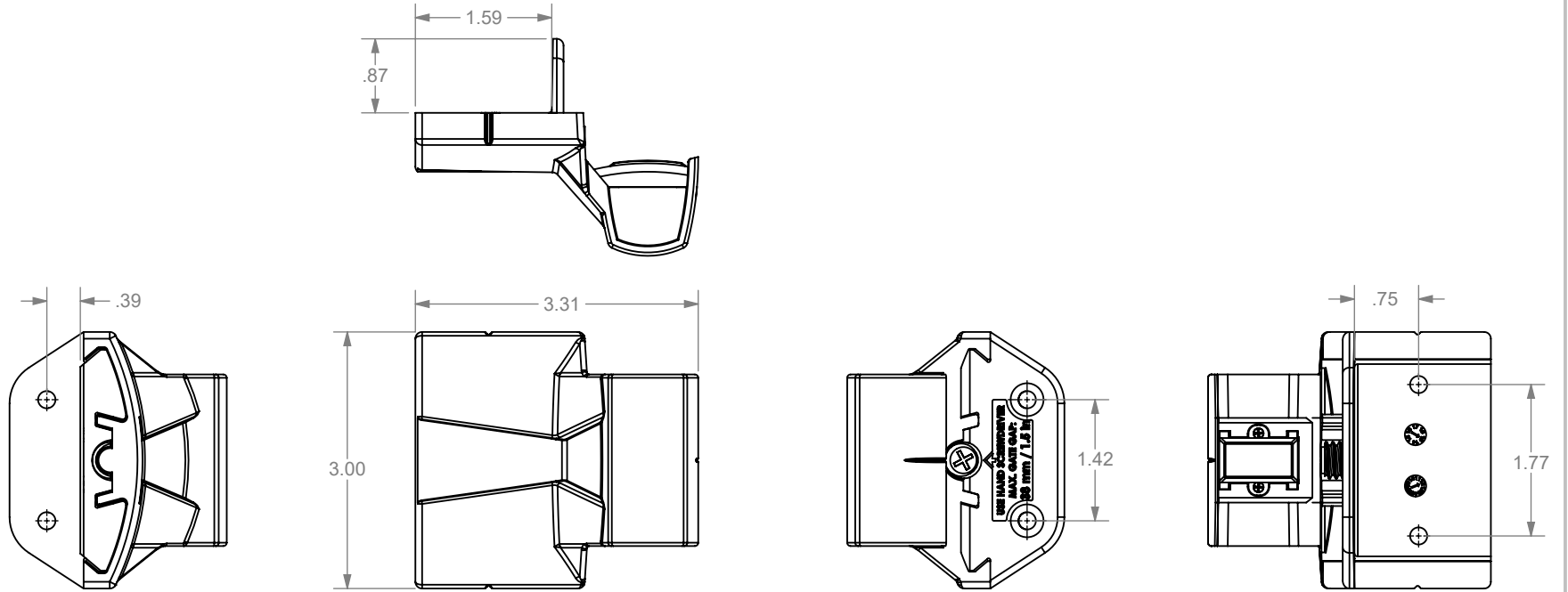

**LOWER MOUNTING BRACKET**

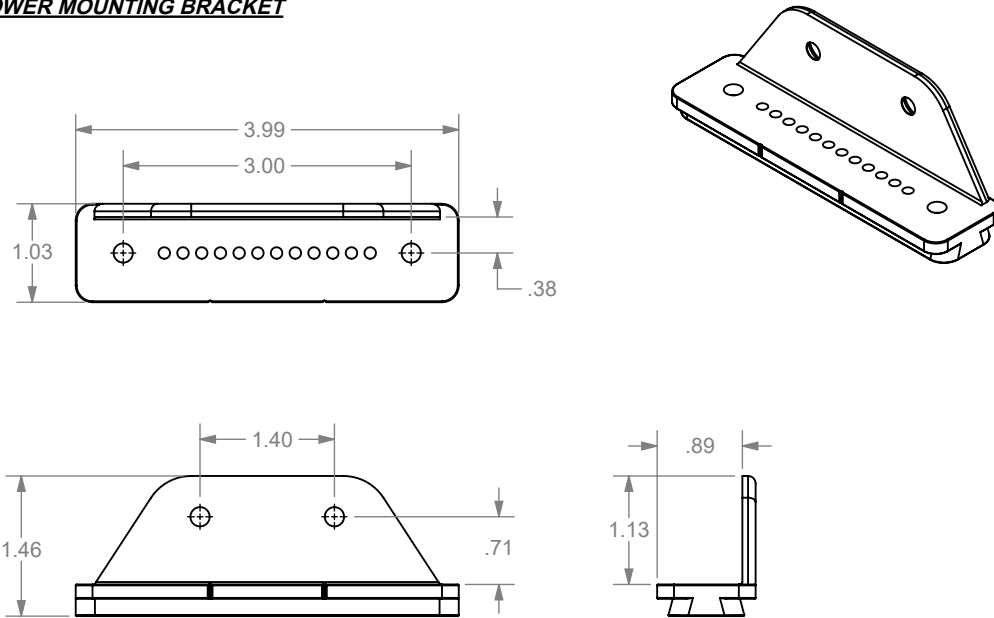

**UPPER MOUNTING BRACKET**

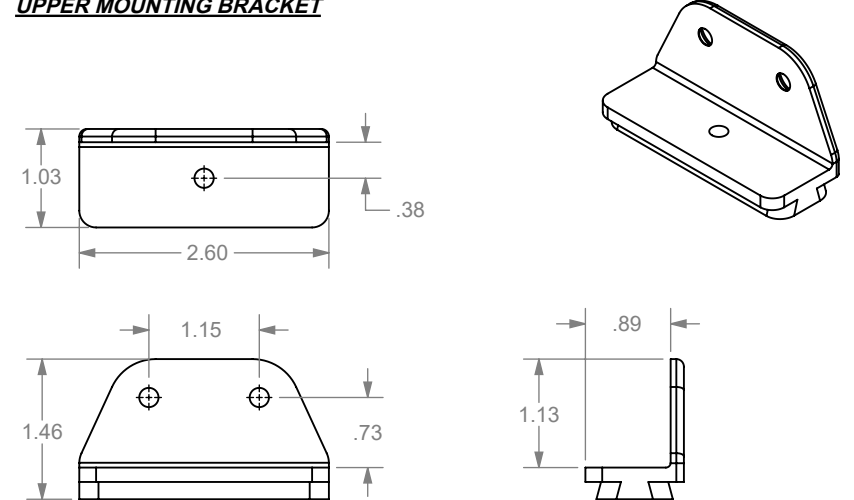

PROPRIETARY AND CONFIDENTIAL  
 THE INFORMATION CONTAINED IN THIS  
 DRAWING IS THE SOLE PROPERTY OF  
 NATIONWIDE INDUSTRIES. ANY  
 REPRODUCTION IN PART OR AS A WHOLE  
 WITHOUT THE WRITTEN PERMISSION OF  
 NATIONWIDE INDUSTRIES IS PROHIBITED.

**TRIDENT™ SS  
 MAGNETIC  
 TOP PULL LATCH**

SIZE DWG. NO. **CS--TRIDENTSS20** REV. -  
 SCALE:1:2 WEIGHT: SHEET 2 OF 2